

8 7 6 5 4

THE INFORMATION CONTAINED IN THIS DRAWING IS THE SOLE PROPERTY OF CRANK BROTHERS. ANY REPRODUCTION IN PART OR WHOLE WITHOUT THE WRITTEN PERMISSION OF CRANK BROTHERS IS PROHIBITED.

NOTES:
1. PACKAGING BOM ON SHEET 2

opium/sageリアハブ
2009/11/29

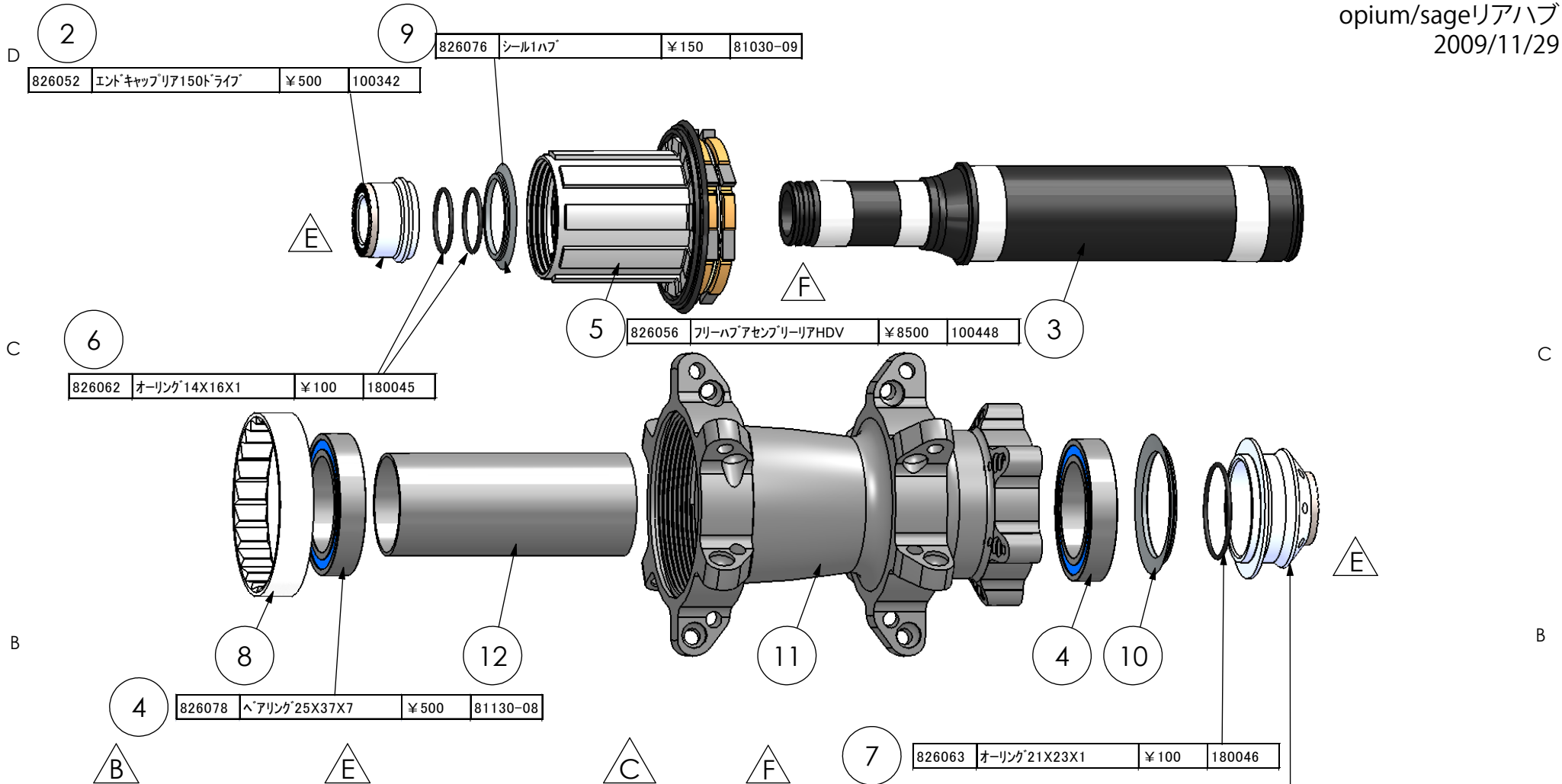

2

| | | | |
|--------|------------------|-------|--------|
| 826052 | エンドキャップリア150ドライブ | ¥ 500 | 100342 |
|--------|------------------|-------|--------|

9

| | | | |
|--------|--------|-------|----------|
| 826076 | シール1ハブ | ¥ 150 | 81030-09 |
|--------|--------|-------|----------|

6

| | | | |
|--------|--------------|-------|--------|
| 826062 | オーリング14X16X1 | ¥ 100 | 180045 |
|--------|--------------|-------|--------|

5

| | | | |
|--------|-----------------|--------|--------|
| 826056 | フリーハブアセンブリリアHDV | ¥ 8500 | 100448 |
|--------|-----------------|--------|--------|

4

| | | | |
|--------|--------------|-------|----------|
| 826078 | ベアリング25X37X7 | ¥ 500 | 81130-08 |
|--------|--------------|-------|----------|

7

| | | | |
|--------|--------------|-------|--------|
| 826063 | オーリング21X23X1 | ¥ 100 | 180046 |
|--------|--------------|-------|--------|

1

| | | | |
|--------|--------------------|--------|--------|
| 826050 | エンドキャップリア150ノドドライブ | ¥ 1000 | 100340 |
|--------|--------------------|--------|--------|

| ITEM # | PART # | NAME | MATERIAL / SIZE / DESCRIPTION | QTY. |
|--------|-----------|--------------------------------------|--|------|
| 1 | 180160 | ASSEMBLY, END CAP REAR 150 HUB LARGE | 6061-T6 ALUMINUM SILVER ANNOIDIZED | 1 |
| 2 | 180159 | ASSEMBLY, END CAP REAR 150 HUB SMALL | 6061-T6 ALUMINUM SILVER ANNOIDIZED | 1 |
| 3 | 100333 | AXLE, REAR HUB 150MM | 7075-T6 ALUMINUM BLACK ANNOIDIZED | 1 |
| 4 | 81130-08 | CARTRIDGE BEARING 25X37X7 | 6805 LLB C-3 (25 x 37 x 7 mm) Grease: 80% Mobil HP 222 ABEC Level 3 | 2 |
| 5 | 100448 | CASSETTE ASSEMBLY, HD REAR HUB | ALUMINUM / STEEL | 1 |
| 6 | 180045 | ORING | BUNA-N, BLACK, 13.8X15.8X1 TO 14X16X1 | 2 |
| 7 | 180046 | ORING | BUNA-N, BLACK, 20.5X22.5X1 TO 21X23X1 | 1 |
| 8 | 100346 | RING, RATCHET TEETH | STEEL, STANDARD PART | 1 |
| 9 | 81030-09 | SEAL 1, HUB | RUBBER | 1 |
| 10 | 81040-03 | SEAL 2, HUB | RUBBER | 1 |
| 11 | 100350-01 | SHELL, REAR 150 V HUB | 6061-T6 ALUMINUM ANODIZED COOL GRAY 11C | 1 |
| 12 | 100354 | SPACER REAR 150MM | 6061-T6 ALUMINUM ANODIZED BLACK | 1 |

8 7 6 5